

ARTEC-320

Two way, double 10"
Installation Line Array



- » Two way passive system
- » 2 x 10" (2.5" VCD)
- » 1 x M-75 compression driver (3" VCD)
- » Aluminium Waveguide
- » Top grade Birch cabinet construction
ISO-flex polyurea paint
- » Rigging hardware for permanent installation compatible with the ARTEC-322S

The ARTEC-320 system is a two-way line array system for installation with dual 10" low frequency speakers, and a compression driver with 3" titanium diaphragm and 1.5" exit for the high frequency reproduction.

The 15mm birch plywood cabinet construction offers an ultra-compact design which is available in black or white.

The high frequency waveguide is the same as the waveguide incorporated in the prestigious event series.

The impedance of the system is 16 ohm, due to the use of 8 ohm speakers in series and the design of the passive crossover, which optimizes the horizontal coverage in the frequency bandwidth near the X-over point.

The JP-320 (included in ARTEC-320) are accessories that permit the system array assembly, whereas the AX-AR3 (optional) is needed for the rigging system.

The system's width is the same as the ARTEC-322S, so a cluster with subwoofers can be installed by the use of the same accessories JP-320.

Technical Specifications

Peak Power Handling	2000 W
RMS (Average) Power Handling ¹	500 W
Frequency Range (-10dB)	60 Hz - 20 kHz
Nominal Impedance	16 ohms
On-axis Sensitivity 1 W / 1 m	99 dB SPL
Maximum Peak SPL at 1 m ²	132 dB
HF Horn Coverage Angles (-6dB)	90° x Splay Dependent
Enclosure Material	Birch Plywood
Color / Finish	Black or White FX fiberglass paint
Transducers / Replacement Parts	LF: 2 x 10MI/GM-10MI HF: M-75/GM-M75N
Connectors	Terminal Strip
Dimensions (H x W x D)	27 x 70 x 36 cm 10.6 x 27.6 x 14.2 in
Weight	26.5kg (58.3 lb)
Accessories	AX-AR3 / AX-AR3-W JP-320 / JP-320-W

Dimensions

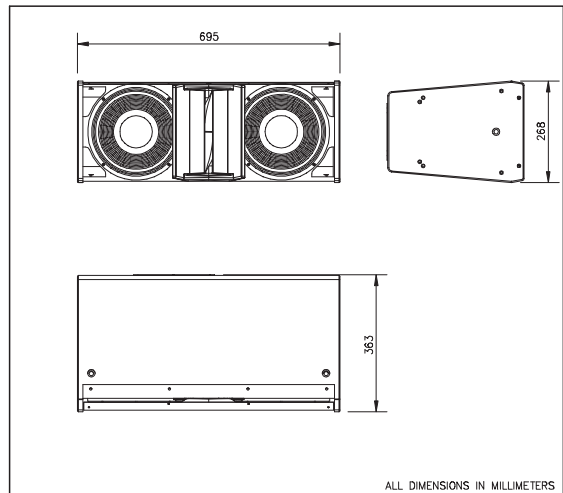

Notes:

1. Based on a 2 hour test continuously applying 6dB crest factor pink noise.
2. Maximum calculated Peak SPL based on sensitivity and RMS power handling.

Frequency Response

Shows the frequency response (processed) at 1 m of a unit radiating to an anechoic environment and driven by a 4 V swept sine wave signal.

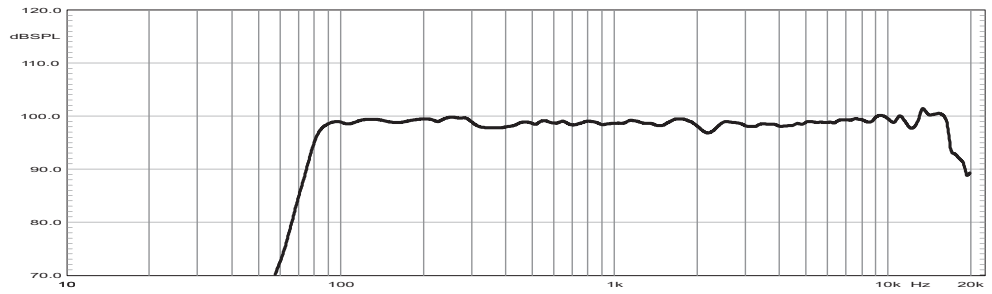

Horizontal Directivity

Shows normalized horizontal isobar plot.

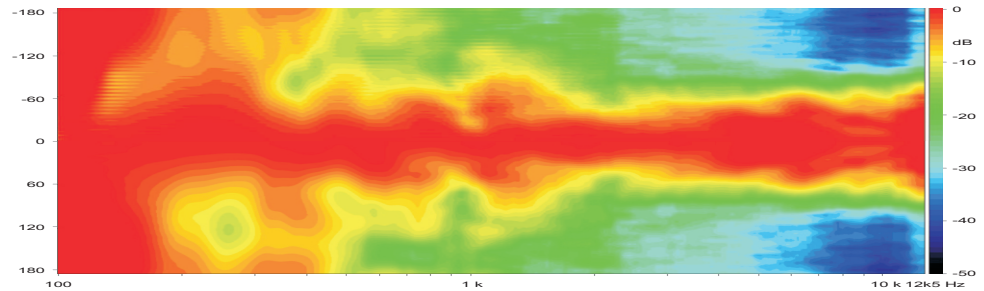

Vertical Directivity

Shows normalized vertical isobar plot.

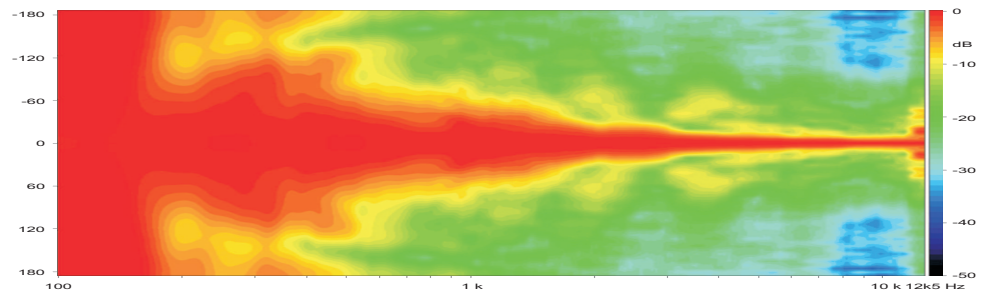

Polar Response

Shows the 1/3 octave band horizontal (left) and vertical (right) polars for the indicated frequencies. Full scale is 30 dB, 6 dB per division.

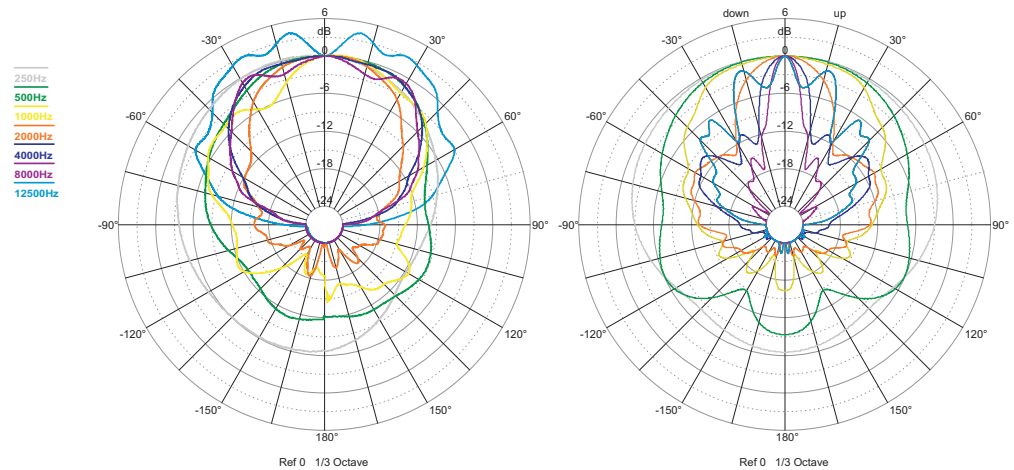

Recommended processor settings (DAS DSP-2060A or DSP-4080)

High Pass Filter Butterworth 24dB/oct at 90 Hz

Low Pass Filter ----

Limiters 400 W RMS; Threshold +8dBu (32dB amplifier Gain), peak limiter +11dBu, 8ms attack time, release x 16

EQ (1 cabinet FLAT response) 3k43Hz Q7 -3dB, 2k47Hz High Shelving Q0.71 -2dB, 8k81Hz Q3 -7dB

NOTES. 1.Frequency response: referred to 1 m; low end obtained through the use of near field techniques; one-third octave smoothed for correlation with human hearing. 5.Polars were acquired by placing the unit on a computer controlled turntable inside our anechoic chamber. Measurement distance was 4 m.

Product improvement through research and development is a continuous process at D.A.S. Audio. All specifications subject to change without notice.

DAS Audio Group, S.L.
C/. Islas Baleares, 24
46988 Fuente del Jarro
Valencia, SPAIN
Tel. +34 96 134 0860

DAS Audio of America, INC.
6900 NW 52th Street
Miami, FL. 33166 - U.S.A.
TOLL FREE: 1 888 DAS 4 USA

DAS Audio Asia PTE. LTD.
3 Temasek Avenue, Centennial
Tower #34-36
Singapore 039190
Tel. +65 6549 7760

DAS do Brasil LTDA.
Rua Dos Andradas, 382 SL
Santa Efigênia, São Paulo
Brasil. CEP: 01208-000
Tel. +551133330764